

VORLESUNG 12

Vorlesung
Humboldt-Universität zu Berlin
Institut für Physik

Biologische Physik

Die Dynamik biologischer Prozesse im menschlichen Körper

Richard Weinkamer

Max Planck Institute of Colloids and Interfaces
Department of Biomaterials
Potsdam

richard.weinkamer@mpikg.mpg.de



**Max Planck Institute
of Colloids and Interfaces**



6 Endocrine system – hormone physiology

hormones send messages or commands
from one part of the organism to another

tasks of the endocrine system:

- whole-body metabolism – energy (glucose metabolism, ...)
- maintenance of internal environment (water, sodium, calcium, ...)
- growth and development
- reproduction and sexual development

endocrine system sends signals to the body by
secreting hormones directly into the circulation

HORMONES vs. CYTOKINES





6 Endocrine system – hormone physiology

“classical” endocrine glands:

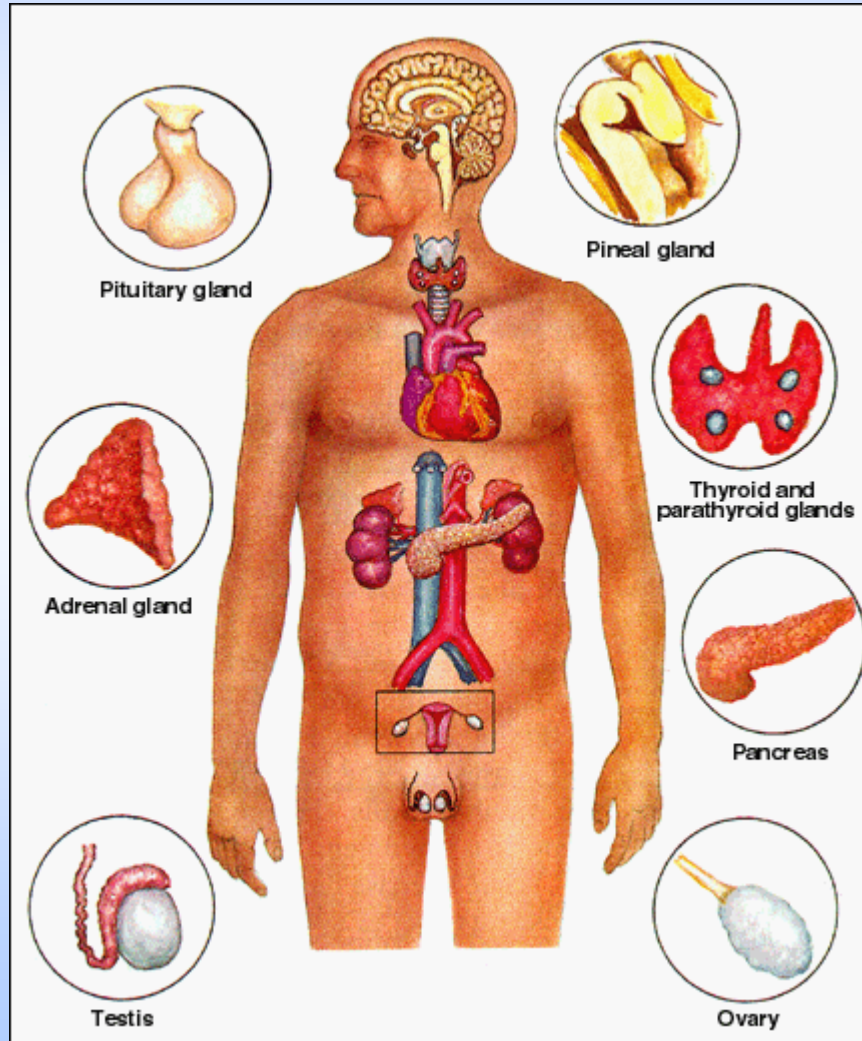

- pituitary and hypothalamus (Hypophyse, Hypothalamus)
- thyroid gland (Schilddrüse)
- parathyroid glands (Nebenschilddrüsen)
- adrenal gland (Nebenniere)
- pancreas (Pankreas = Bauchspeicheldrüse)
- testes and ovaries (Hoden, Ovarien = Eierstöcke)

nonclassical endocrine organs:

heart, brain, kidney, liver, ...





6 Endocrine system – hormone physiology

composition of hormones:

- protein or peptide variety
- glycoproteins
(luteinizing hormone LH, follicle-stimulating hormone FSH, ...)
- catecholamines (modification of tyrosine) (thyroxine T4)
- steroid hormones (precursor cholesterol)
(cortisol, aldosterone, estradiol, testosterone, ...)
- eicosanoids (precursor fatty acid) (prostaglandins, ...)
- ions such as calcium have hormone-like effects

thyroxine:

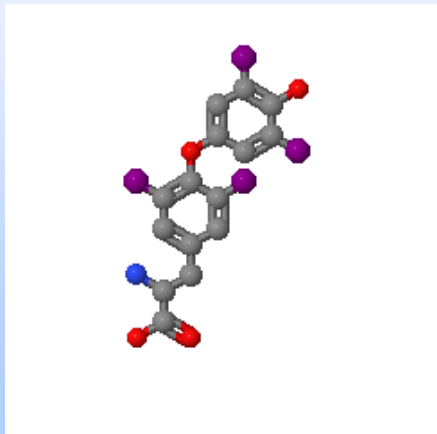

FSH:

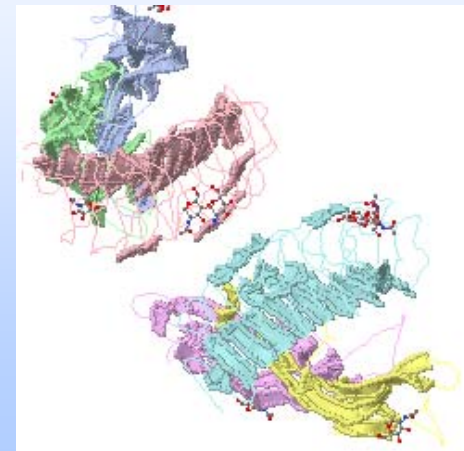



6 Endocrine system – hormone physiology

how hormones work:

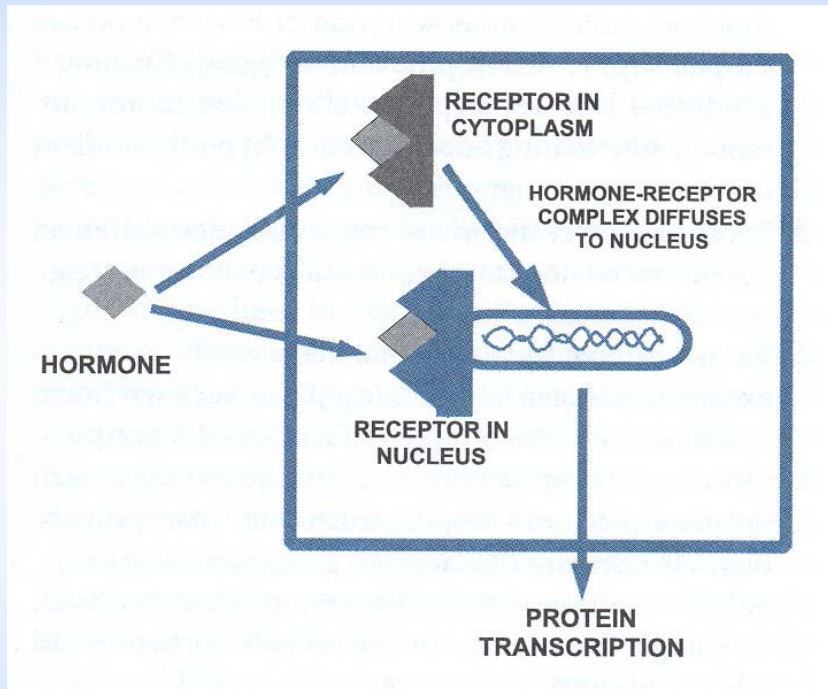

non-polar hormones –
directly to the nucleus

carrier proteins

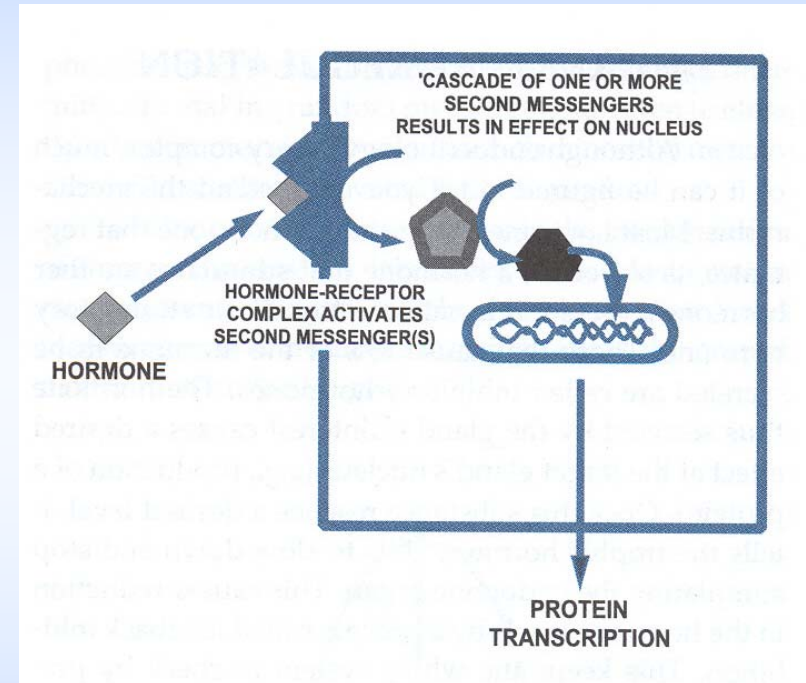

polar hormones –
bind to cell membrane receptors





6 Endocrine system – hormone physiology

hormonal regulation:

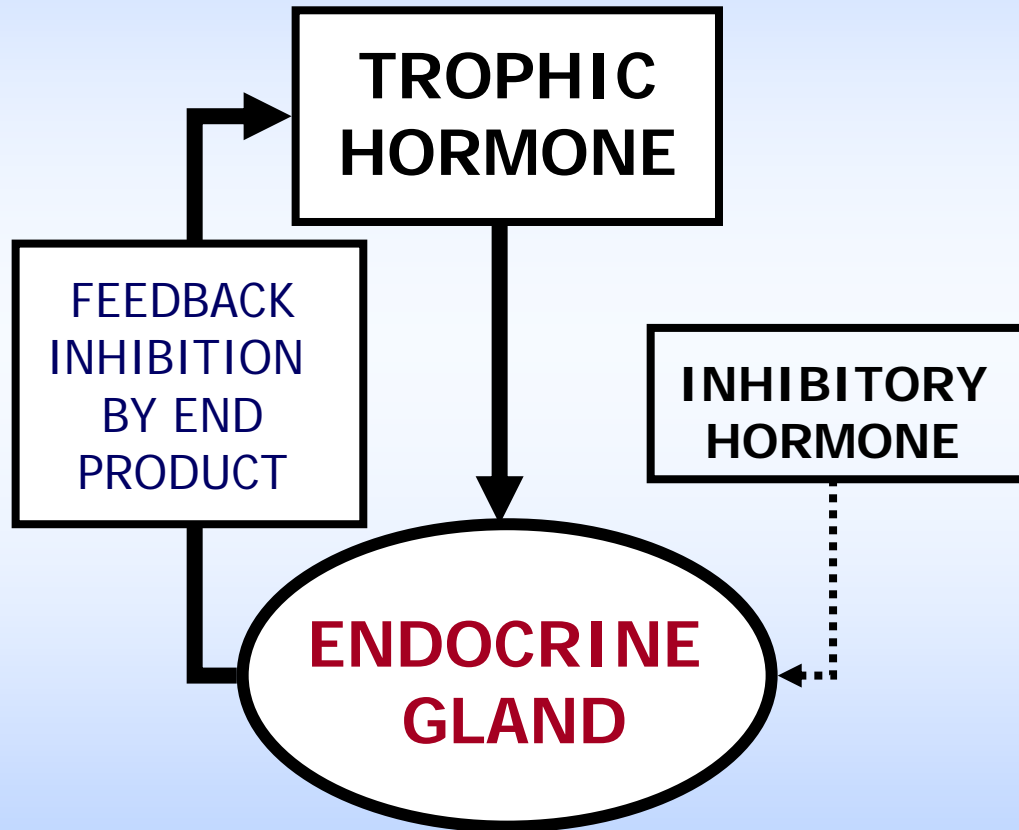

endocrine disorders:

- target organ is damaged or absent and produces insufficient hormone (hypofunction)
- target organ produces too much hormone (hyperfunction)
- receptor defect/hormone resistance
- excess trophic hormone
- deficiency of trophic hormone
- administration of excess exogenous hormone





6 Endocrine system – hormone physiology

example: THYROID

thyroid regulation:

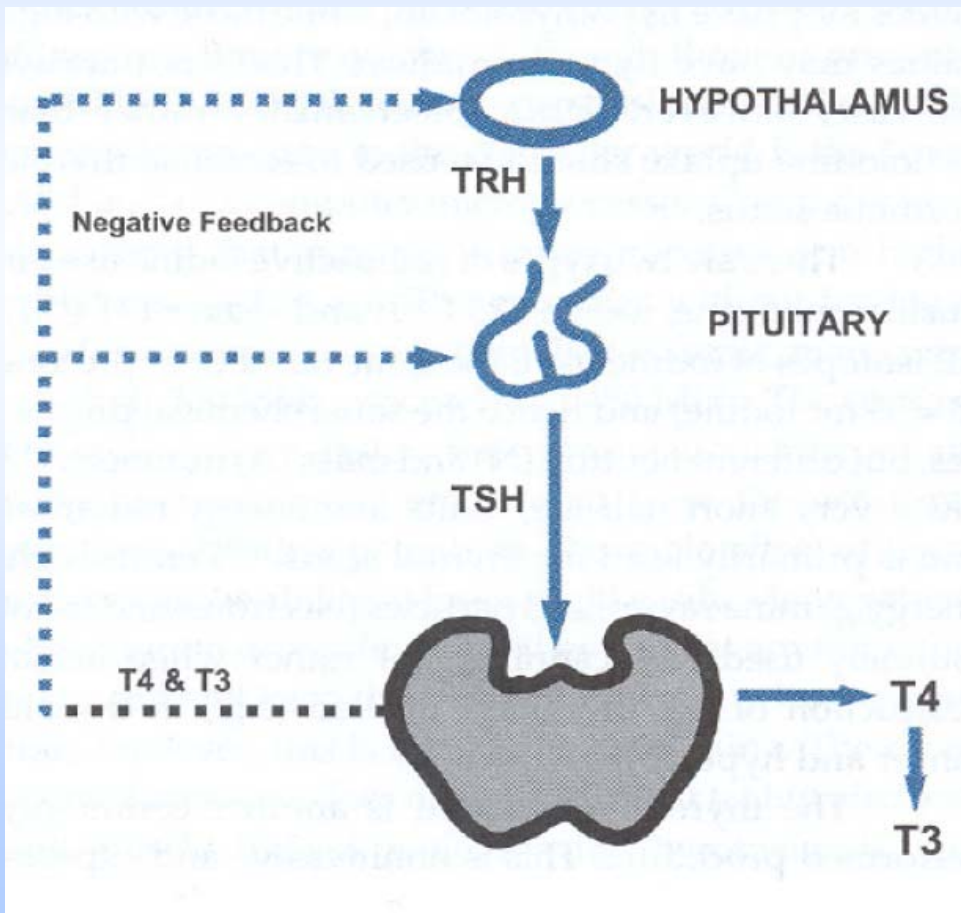

thyroid disorders:

- primary hypothyroidism (e.g. Hashimoto's thyroiditis)
- primary hyperthyroidism (e.g. Graves' disease)
- thyroid receptor defect/hormone resistance
- secondary hyperthyroidism (increased TSH levels)
- secondary hypothyroidism (decreased TSH levels)
- „hamburger thyrotoxicosis“





6 Endocrine system – hormone physiology

example: PITUITARY AND HYPOTHALAMUS THYROID

„master glands“:

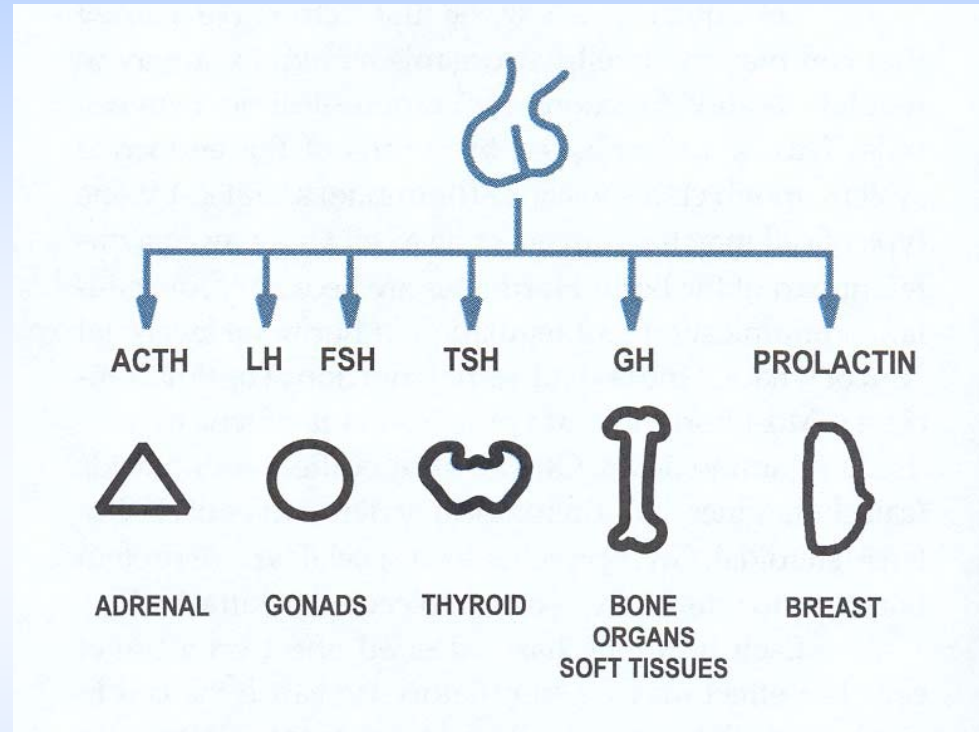

ACTH: adrenocorticotrophic hormone or corticotropin – adrenal cortex

GH: growth hormone or somatotropin – bone and muscle

PRL: prolactin – milk producing glands of breast

TSH: thyroid-stimulating hormone or thyrotropin – thyroid

LH: luteinizing hormone – ovaries and testes

FSH: follicle-stimulating hormone – ovaries and testes





6 Endocrine system – hormone physiology

example: GROWTH HORMONE

mediated by insulin-like growth factor I (IGF-I)

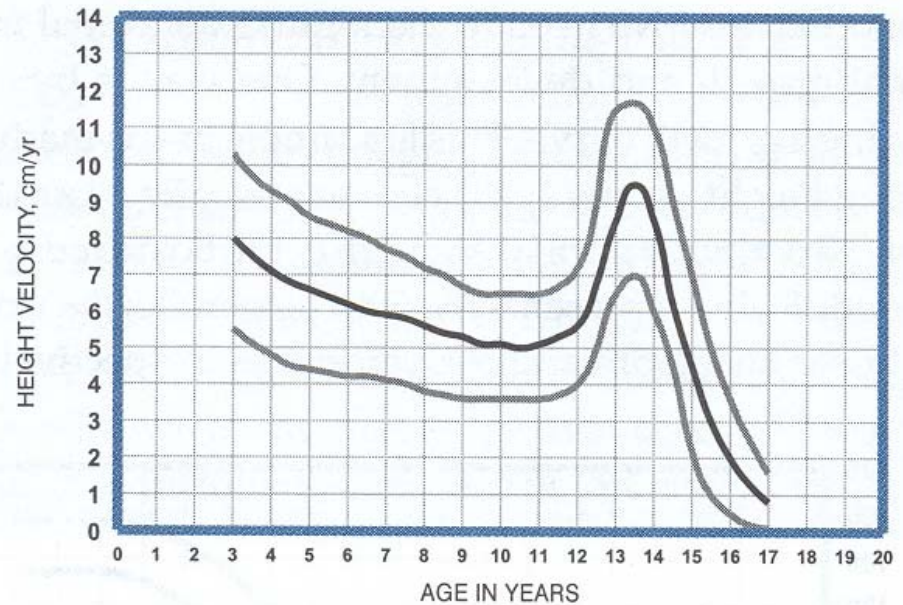
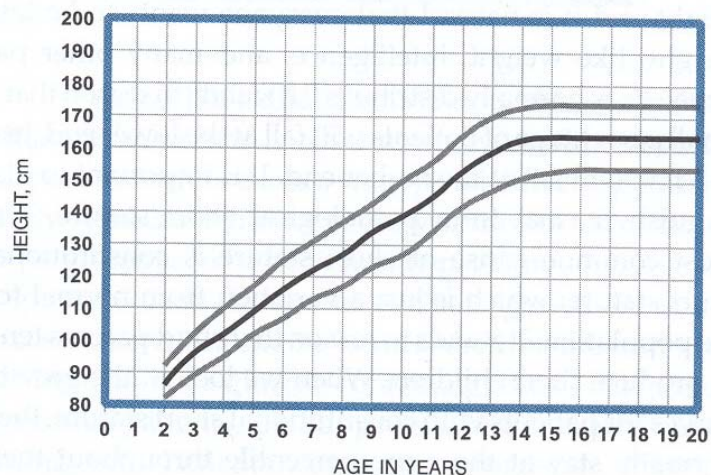
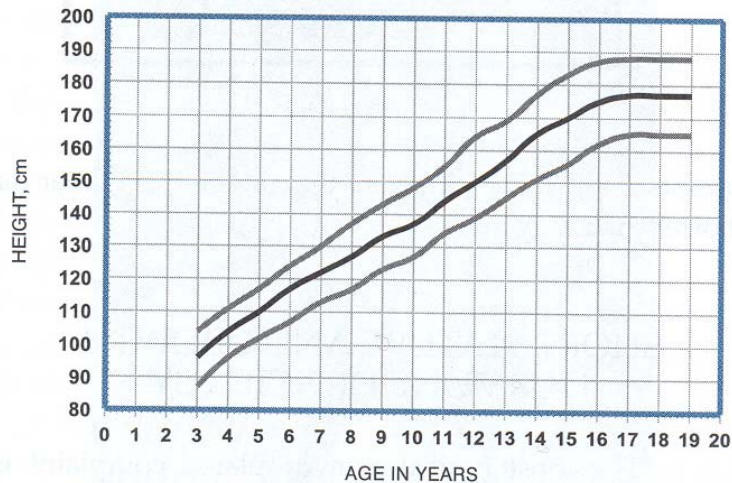



6.1 Calcium Metabolism

calcium involved in:

- muscle contraction
- synaptic transmission in the nervous system
- platelet aggregation and coagulation
- intracellular messenger

therefore
**TIGHTLY
REGULATED**

parathyroid hormone (PTH):

increased resorption of Ca from bone
increased reabsorption of Ca from the kidney
increased calcium absorption from the intestine

calcitriol (active metabolite of vitamin D):

increased calcium absorption in the intestine

calcitonin:

weak antagonist of PTH

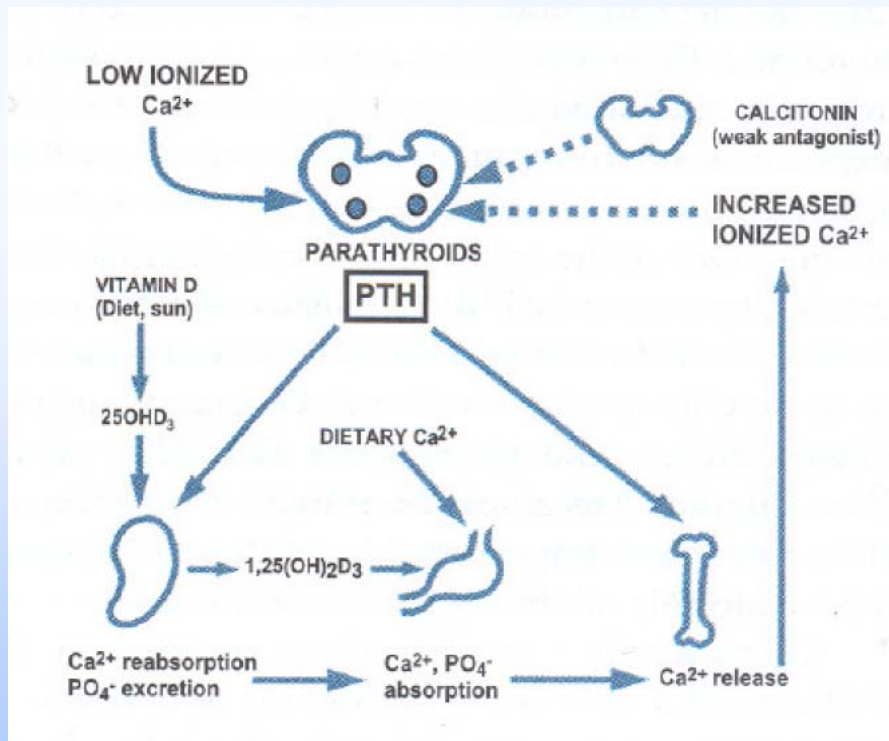



6.1 Calcium Metabolism

El-Samad et al.,
J theor Biol (2002) 214, 17-29

feedback loop of calcium homeostasis:

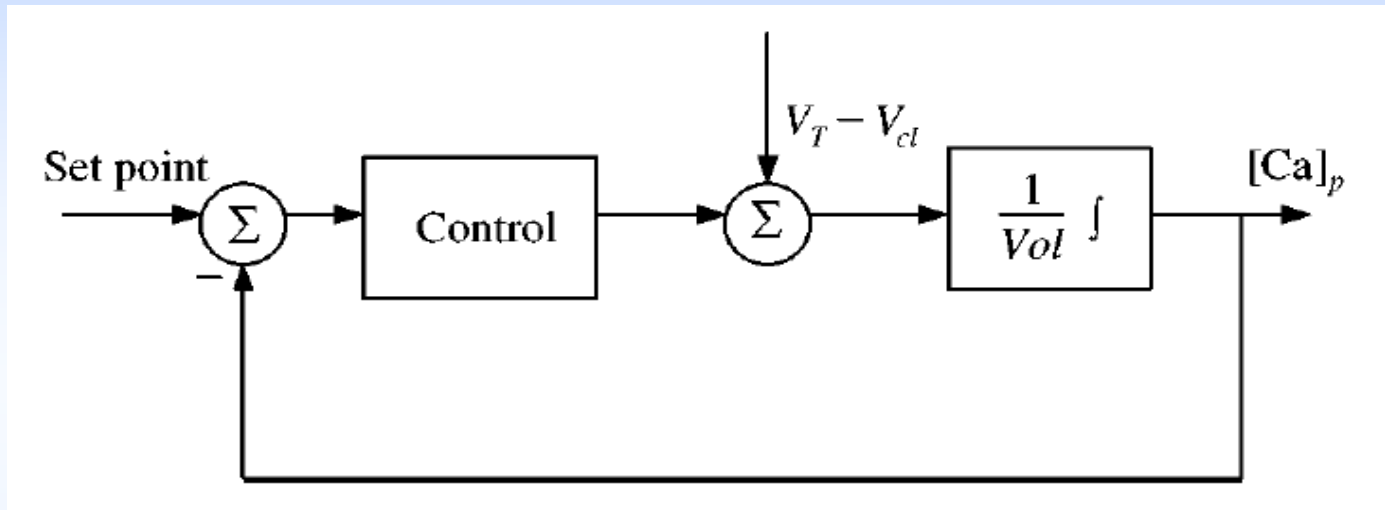

$[Ca]_p$... plasma calcium concentration

$$\frac{d}{dt} [Ca]_p = \frac{1}{Vol} (V_T(t) - V_{cl}(t))$$

feedback:

- setpoint r
- tracking error e

$$e(t) = r - [Ca]_p(t)$$





6.1 Calcium Metabolism

proportional feedback:

$$V_T = K_p e$$

integral feedback:

$$V_T = K_p e + K_i \int e$$

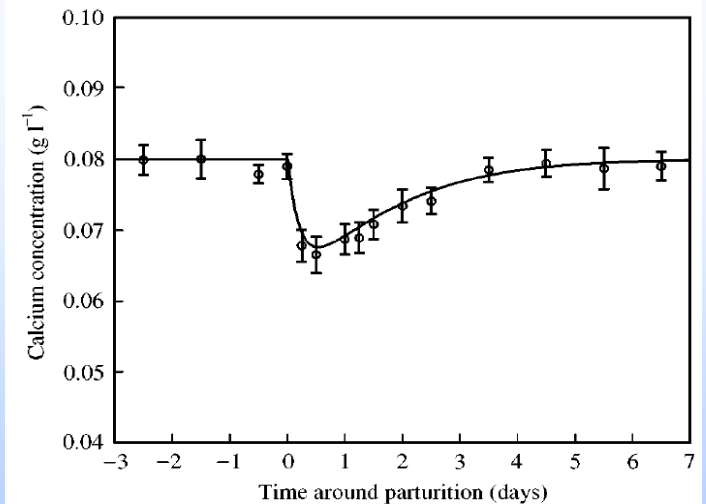
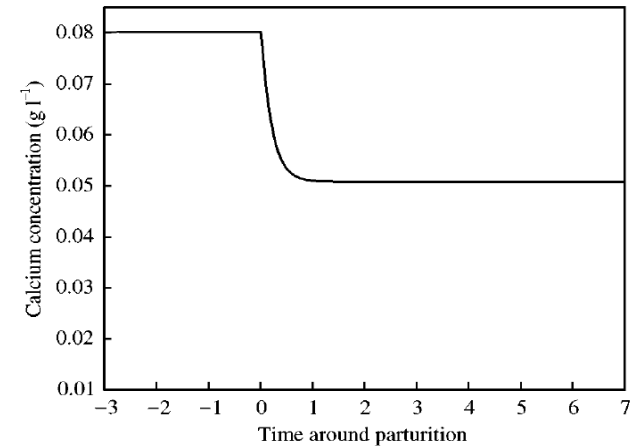
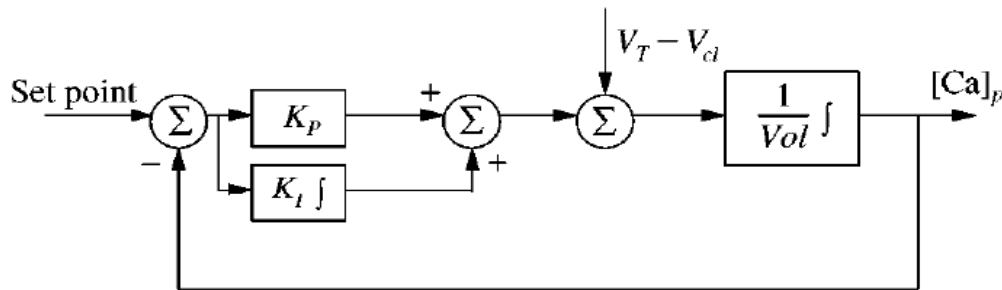

El-Samad et al.,
J theor Biol (2002) 214, 17-29





6.1 Calcium Metabolism

realizing integration by means of hormones:

only one hormone:

$$V_T \propto [\textit{Hormone A}]$$

$$\frac{d}{dt} [\textit{Hormone A}] \propto \left(\textit{error} + K \frac{d}{dt} \textit{error} \right)$$

two hormones:

$$V_A \propto [\textit{Hormone A}] \propto \textit{error}$$

$$\frac{d}{dt} [\textit{Hormone B}] \propto [\textit{Hormone A}] \quad V_B \propto [\textit{Hormone B}]$$

for calcium homeostasis:

- Hormone A: PTH
- Hormone B: calcitriol

non-linear effects: "milk fever"

